

MUFLE[®]
WATER CONVEYING SYSTEMS



**BEST
CHOICE
GUARANTEED**



Before 2004 there was no Standard regulating the production and marking of drainage channels. The issue of **EN 1433:2004** was a step forward in manufacturing high-quality products in compliance with the **CEN** (European Committee for Standardisation).

This European Standard defines the requirements for linear drainage channels for the collection and conveyance of surface water when installed within areas subjected to pedestrian and/or vehicular traffic.

The Standard **EN 1433:2004** specifies definitions, classes, design and testing requirements, marking and quality control for drainage channels.

It also establishes the conditions for the **CE** marking of drainage channels. The clauses of this European Standard meet the requirements of the mandate given under the EU Construction Products Directive (89/106/EEC) and the relevant strict and precise technical regulations on designing and manufacturing criteria.

The CE marking to affix must be indelible and clearly visible on the product. It guarantees that the product meets all the essential protection and safety requirements for the consumer. The CE marking is to be seen as the passport for the free movement of the product within the Common Market.

MufleSystem Srl has always focused on the quality and safety of its products, thus being granted the corporate certification **ISO 9001:2000** and the product certification according to **EN 1433:2004** for the range **MufleDrain** from IGQ (Italian Quality Assurance Institute). In order to ensure all essential safety features, the **CE** marking has been affixed on all the products since 2005.

The spreading of accurate information on the contents of Standard **EN 1433:2004** acts as a guarantee for the customer, who is able to recognise conforming products thanks to the following guidelines.



1 Drainage channel

The European Standard EN 1433 defines a **DRAINAGE CHANNEL** as “a linear assembly composed of prefabricated units permitting the collection and conveyance of water along its total length”. The Standard also distinguishes “**Type I**” channels (**fig.a**) from “**Type M**” channels (**fig.b**). By definition, the former “require no further support to accommodate the vertical and horizontal loads in service”, while the latter need additional support.

The **MUFLEDRAIN** - marked drainage channel manufactured by **MufleSystem** is a **Type M** channel.

The **DRAINAGE CHANNEL** is a drainage line whose length varies according to the different needs and cases.

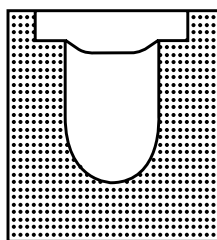

fig.a

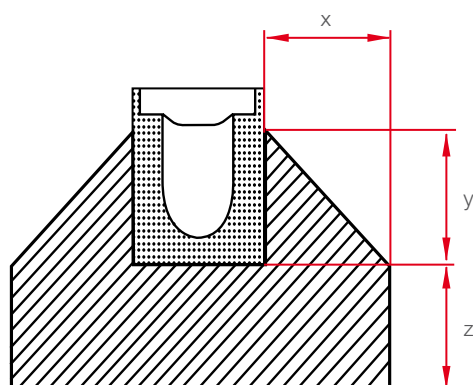

fig.b Key: x,y and z dimension of additional support.

It is made up of a certain number of units defined as **grid units**”.

In compliance with §7.17 of the Standard, the “manufacturer” is required to provide the “instructions for specific haunching of drainage channel units”. The following information must be given too: dimensions of concrete bed (H) and haunching (S) (**fig.c**), the concrete class required, and reinforcement details if any, to meet the load classification on the product at the place of installation.

Documented instructions shall also define the jointing and sealing of adjacent channels. To this end §7.5.1 of EN1433:2004 specifies as follows: “The joint between channel units shall be designed in such a way that it may be durably sealed [...] the manufacturer shall state the method of installation in his instructions”.

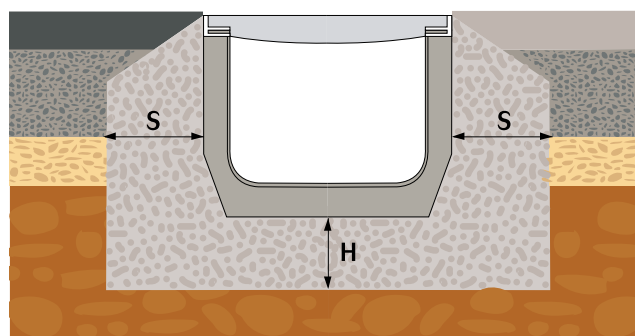

fig.c

Standard EN 1433 defines a DRAINAGE CHANNEL as “a linear assembly composed of prefabricated units permitting the collection and conveyance of water along its total length”

**EN1433
GUARANTEE**

2 Grid unit

Standard EN 1433:2004 defines a grid unit as “prefabricated drainage channel unit with an open top with inserted gratings and/or covers”.

So a grid unit (**fig.d**) is the basic unit used to make up the whole drainage line. It includes a “channel body” and a grating and/or cover defined as “removable parts from the grid unit which permits, in the case of gratings, the intake of water”.

Example of grid unit (**fig.e**).

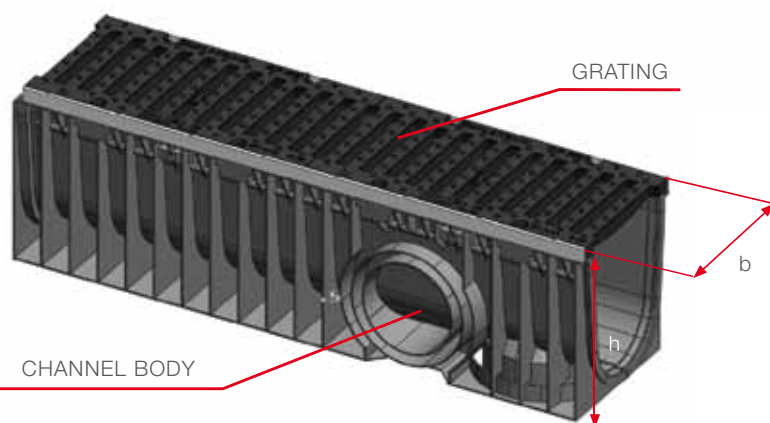
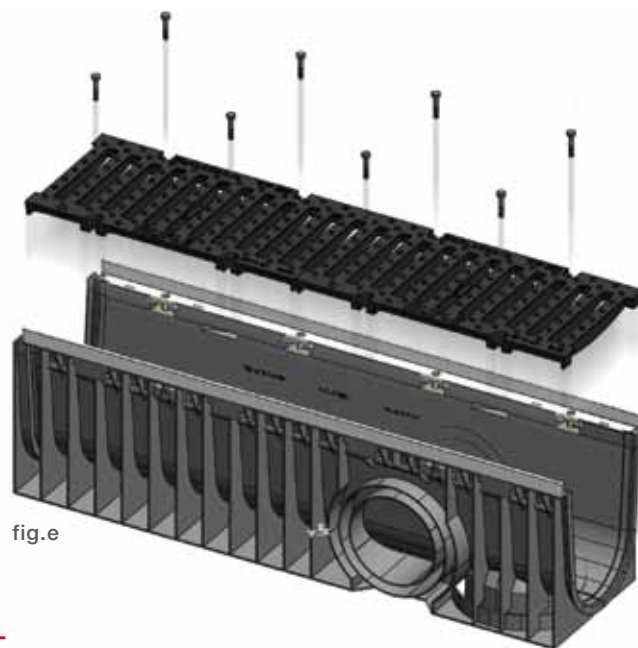

fig.d Key: h, b: internal dimensions (wetted perimeter).



3 Pass-through dimension CO (or clear opening)

The pass-through dimension **CO** or clear opening is defined as “Unobstructed width between the seating of the grid units”. The clear opening is expressed in millimetres (mm) (**fig.f**).

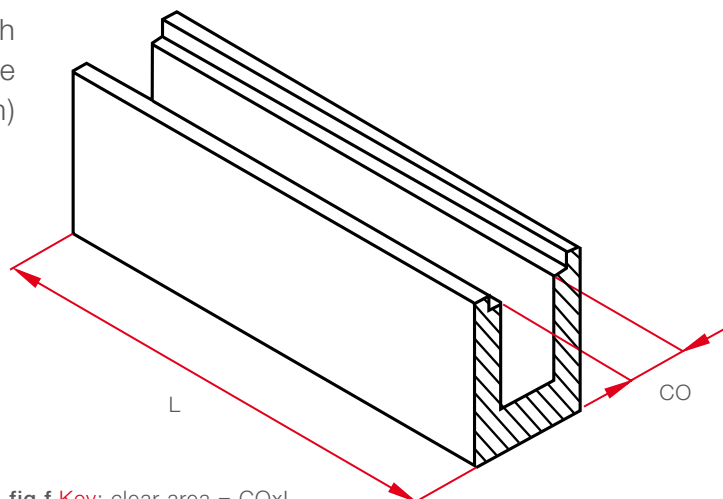

fig.f Key: clear area = $CO \times L$

4 Contact surfaces and trafficked edges

Standard EN 1433:2004 also specifies the compulsory protections to be applied to the drainage channels: “Metal edges or similar components applied to or inserted into the channel body as seating for gratings and covers and as a protection of the channel body against damage from traffic”.

This protection is compulsory for grid units of classes D400 to F900, and recommended for class C250, in compliance with §7.8 of the Standard. In the case of classes D400 to F900, the edge and contact surface protection shall be secured against disconnection from the channel units by traffic and shall be made of either cast iron or steel with thicknesses according to table. (table 1).

MufleSystem has complied with said essential specification of the Standard by designing “edges” made of either galvanised/stainless-steel or spheroidal cast iron to be fixed to the channel body by means of mechanical hooks. This resulted in the new models named “WING” and “PLUS”. Fig.g shows a clear example of what is stated in this paragraph..

CLASS	MINIMUM THICKNESS mm.	
	Trafficked edge e	Contact surface d
C 250	2	1
D 400	4	2
E 600 - F 900	not less than that required for Class D400	

table 1

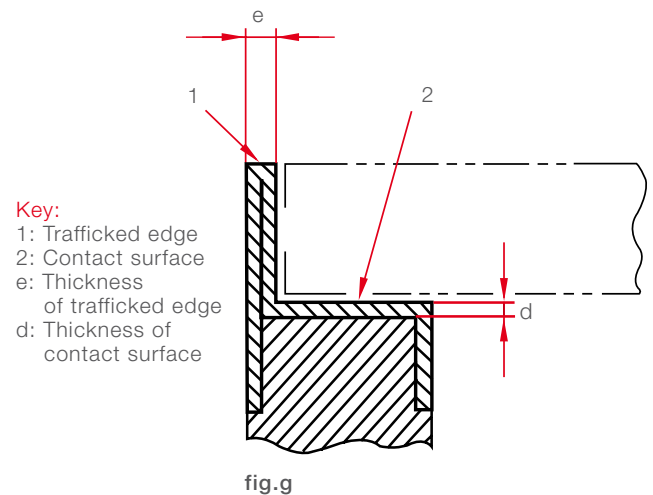

5 Depth of insertion of gratings and covers

Drainage channels of classes D400 to F900 shall have a depth of insertion “A” (see figure h) of at least 50 mm, in compliance with §7.6. In the same paragraph the Standard specifies as follows: “This requirement does not apply if the covers or gratings are made secure against displacement by traffic by means of a locking device [...]” (fig.h).

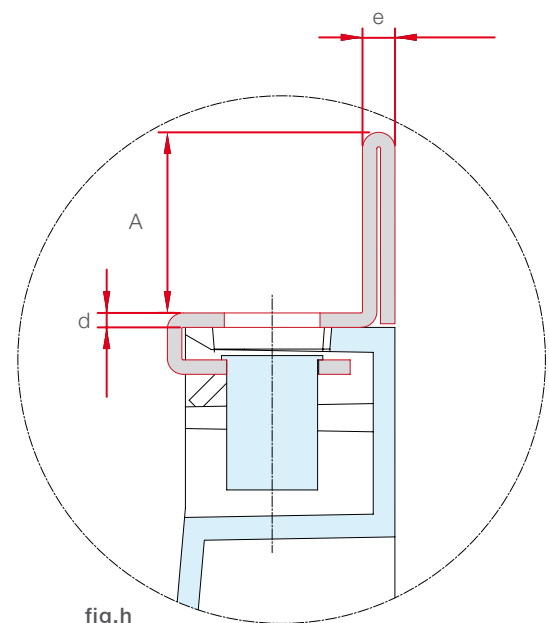

Key:
e: Thickness of trafficked edge
d: Thickness of contact surface
A: Depth of insertion of the gratings

Legend:
Metal edge
Drainage channel

6 Groups of installation



Group 1 (A15): Areas which can only be used by pedestrians and pedal cyclists.



Group 2 (B125): Footways, pedestrian areas and comparable areas, private car parks or car parking desks.



Group 3 (C250): Kerb sides and non-trafficked areas of hard shoulders and similar.



Group 4 (D400): Carriageways of roads, hard shoulders and parking areas, for all types of road vehicles.



Group 5 (E600): Areas subjected to high wheel loads, e.g. ports and dock sides.



Group 6 (F900): Areas subjected to especially high wheel loads e.g. aircraft pavements.

Typical highway cross section showing the location of some installation groups

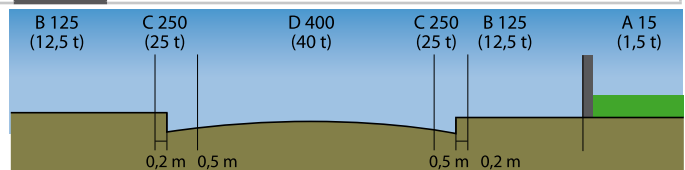

7 Materials

Chapter 6 of **EN 1433** is about the materials that **can** be used to manufacture the channels and gratings. In particular, §6.1.1 specifies that “drainage channels can be made of:

- flake graphite cast iron;
- spheroidal graphite cast iron;
- cast steel;
- rolled steel;
- stainless steel;
- reinforced or unreinforced concrete;
- synthetic resin concrete;
- concrete with fibre;
- one of the materials **a) to f)** combined with concrete/synthetic resin concrete with fibre.

“For materials other than those listed above, [...] the product shall comply with any relevant provisions valid in the country of use [...]”.

The **MUFLEDRAIN** channels are made of high-density Polyethylene (PE-HD).

As the raw material used is not included in the list above, the product must comply with the provisions on plastic materials.

The Italian Quality Assurance Institute (IGQ) worked out for MUFLE a Certification Scheme (SC011) which includes a section where the “relevant provisions” on plastic materials are summarised.

The Scheme also includes ordinary load-resistance tests for gratings and grid units, manufacturing-process checks and project audits to make sure they meet the Standard requirements. The finished product made of said materials must meet the following requirements:

- black colour;
- raw-material density (PE-HD) = 930 Kg/m³ or higher;
- yield point of the channel = 22 MPa or higher.

According to said specifications the **MufleSystem** channels are black, they are made from high-density polyethylene (955 kg/m³) and they have a yield point of 27,6 MPa.

The IGQ, located at 336 Viale Sarca, Milan, was acknowledged by the Italian Ministry for Production as qualified to perform type tests on the products under **EN 1433** with notification No. 1608.

Grating and cover marking

THE GRIDS AND COVERS MUST BE MARKED AS FOLLOWS:

- a) Standard number EN1433;
- b) Load class;
- c) Name or identifying mark of the producer;
- d) Name or identifying mark of the company marketing the final system;
- e) Production date or lot;
- f) Certifier mark;
- g) EC compliance mark. The following mark may be added:
- h) Product identification (commercial name from catalogue).

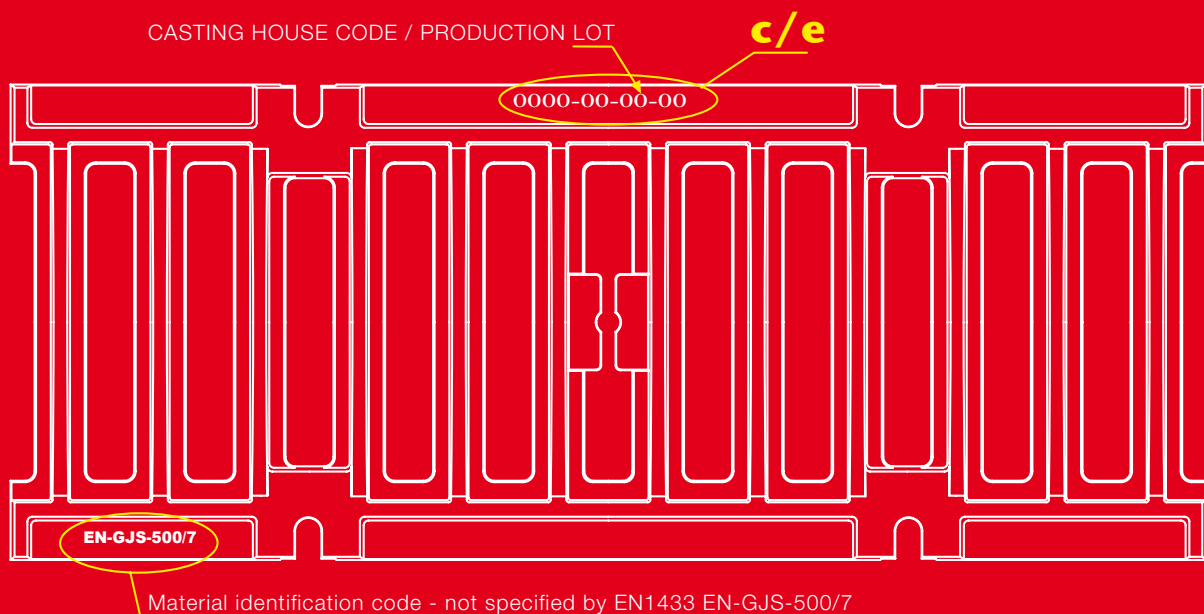
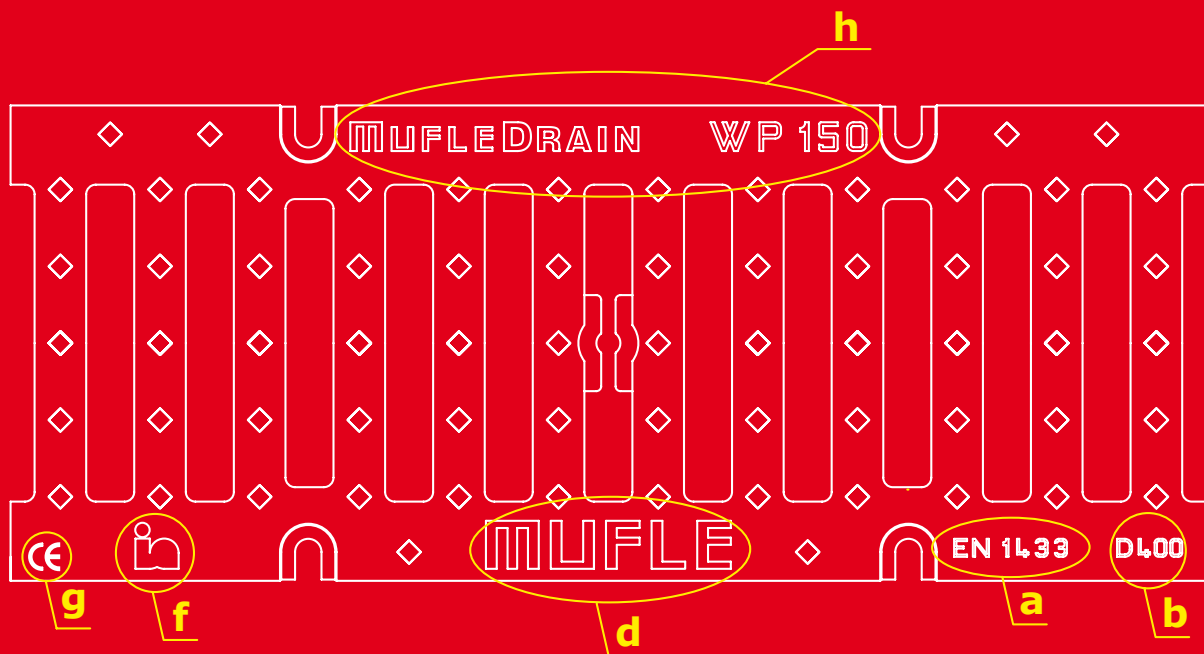

MUFLE[®]
WATER CONVEYING SYSTEMS

**MufleSystem srl Via Dell'Industria 7
62017 Porto Recanati (MC) - Italy
Tel. +39 071 9799122 Fax +39 0717592275
info@mufle.com - www.mufle.com**