

FUNNEL

NEW

The "FUNNEL" is a "high performance" drainage system where a ductile iron "grating" collects rainwater from the surface and, through a ductile iron "cone", conveys it into the HD-PE "pipe" with calculated diameter. Pipes are available with external diameter from $\varnothing 250$ to $\varnothing 1200$.

The system guarantees:

- **flexibility and quick installation:** the FUNNEL is supplied with 6 meters long bars. The easy connection among the bars is assured through the coupling and sealing rings.
- **reliability:** the system has been designed according to the standards of the EN 1433.
- **inspections:** it is possible to inspect the system every 50 cm, simply pulling out the gratings.
- **high hydraulic performance:** guarantees the collection and disposal of huge water flows due to a $\varnothing 110$ outlet every 50 cm.
- is a **patented system**.





ELEMENTS FOR COLLECTED WATER

from D 400
to F 900

FUNNEL

APPLICATIONS

Highways
Logistic Centers
Docks
Airport Areas

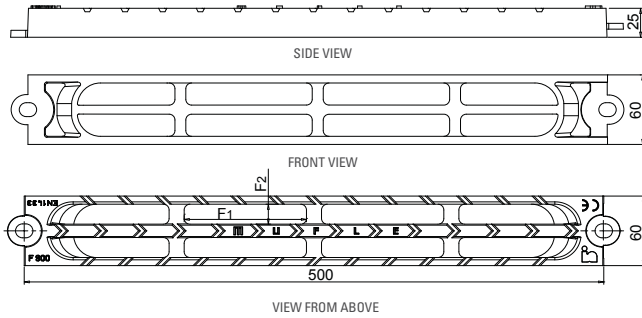

GRATINGS

PRICE €	MATERIAL	DIMENSIONS L x l x h mm	WEIGHT Kg	SECTION DRAINAGE cm ²	OPENINGS F1 x F2 mm	FIXING SYSTEM
	GJS 500/7 ⁶ ductile ironwater based paint coated	500 x 60 x 25	2,60	13,85	105,5 x 17,0	nut

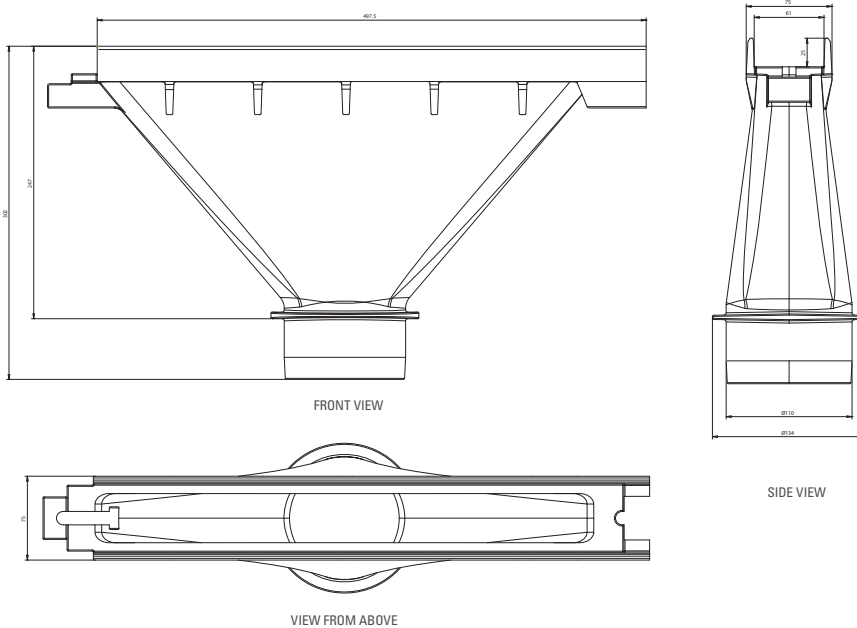

CONES

PRICE €	MATERIAL	EXTERNAL DIMENSIONS L x l x h mm	WEIGHT Kg	OUTLET DIMENSIONS mm	FIXING SYSTEM
	GJS 500/7 ⁶ ductile ironwater based paint coated	498 x 75 x 300	9,9	ø110	nut

6- Classification according to Standard EN 1563 (2009).
N.B. Sizes and weights are subject to usual manufacturing tolerance values.



PIPES

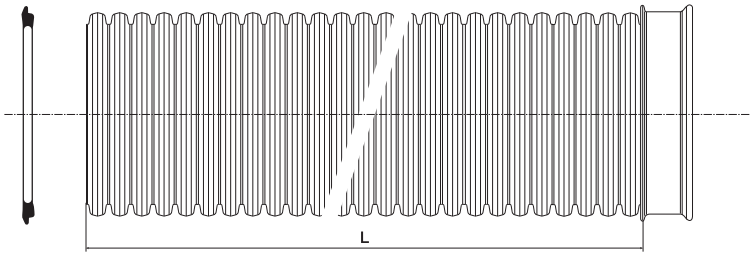

The pipe is a high density co- extruded twin wall pipe, smooth internally and externally corrugated with stiffness class SN8 kN/m² (on request it is possible the class SN 16 kN/m²).

CORRUGATED PIPES IN HD-PE													
DN mm	250	315	350	400	465	500	580	630	700	800	930	1000	1200
DI mm	218	273	300	344	400	427	500	533	600	690	800	853	1025
H* mm	494	559	594	644	709	744	824	874	944	1044	1174	1244	1444

* Total funnel height (pipe + cone + grating).

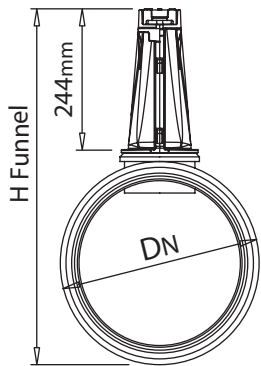

N.B. Sizes and weights are subject to usual manufacturing tolerance values.



HYDRAULIC PERFORMANCE



According to the literature, if the filling percentage of the sewage pipe is fixed to 70%, the water flow rates showed in table "A" a resulting from the slope changes. According to the water flow rate to be drained, it is possible to determine the maximum number of FUNNELS that can be connected to the sewage pipes. The table "B" shows by way of example the values obtained by a water flow rate Q equal to 0.465 l/sec. per meter (calculated for a width of drainage surface equal to 10 meters, with a pluviometric curve $h = 27 \times t^{0.2}$, with run-off time $t_c = 300$ sec. coefficient of outflow $\alpha = 0,85$). If a sewage pipe with a 250 diameter with 0,25% slope is used, it is possible to connect 56 meters of FUNNEL system, before the water falls into the collector or the pipe diameter is increased.

N.B. It is necessary to verify that the water speed has a figure ranging from 0,4-3,0 (m/s). Our technical department stays at your full disposal for further information about the calculations ref. table "B"

Table A

Water Flow rate with filling percentage equal to 70% [l/s]

Diameters [mm]		Sewage pipes SLOPE									
DN	DI	0,05%	0,10%	0,15%	0,20%	0,25%	0,30%	0,35%	0,40%	0,45%	0,50%
250	218	12,1	17,0	20,9	24,1	27,0	29,5	31,9	34,1	36,2	38,1
315	273	22,0	31,1	38,0	43,9	49,1	53,8	58,1	62,1	65,9	69,4
350	300	28,2	39,9	48,9	56,5	63,1	69,2	74,7	79,9	84,7	89,3
400	344	40,7	57,5	70,5	81,4	91,0	99,6	107,6	115,1	122,0	128,6
465	400	60,8	86,0	105,3	121,6	136,0	149,0	160,9	172,0	182,5	192,3
500	427	72,4	102,4	125,4	144,8	161,9	177,3	191,5	204,8	217,2	228,9
630	533	130,8	184,9	226,5	261,5	292,4	320,3	346,0	369,9	392,3	413,5
800	690	260,3	368,1	450,9	520,6	582,1	637,6	688,7	736,3	780,9	823,2
1000	853	458,2	684,1	793,7	916,5	1024,7	1296,1	1212,4	1296,1	1374,7	1449,1
1200	1025	747,9	1057,7	1295,4	1495,7	1672,3	1831,9	1978,7	2115,3	2243,6	2365,0

Table B

Example of calculation of maximum number of "FUNNELS" (m) to be connected for Q = 0,465 l/s

Diameter [mm]		Sewage pipes SLOPE									
DN	DI	0,05%	0,10%	0,15%	0,20%	0,25%	0,30%	0,35%	0,40%	0,45%	0,50%
250	218	25	36	44	51	57	63	68	73	77	81
315	273	47	66	81	94	105	115	124	133	141	149
350	300	60	85	105	121	135	148	160	171	182	191
400	344	87	123	151	174	195	214	231	247	262	276
465	400	130	184	226	261	292	320	345	369	392	413
500	427	155	219	269	311	347	381	411	439	466	491
630	533	280	397	486	561	628	688	743	794	842	888
800	690	559	791	968	1118	1250	1370	1479	1582	1677	1769
1000	853	984	1392	1705	1969	2201	2411	2605	2784	2953	3113
1200	1025	1606	2272	2783	3213	3593	3936	4251	4545	4820	5081



INSTALLATION

FUNNEL

The following installation instructions and the relative drawings are given only as an example not considering any peculiarities of the installation site or soil characteristics, or morphology and position of any possible slope. Any particular installation must be suggested by the project maker.

Step 1

Dig the trench according to the requested dimensions (according to load classes and pipe diameter), indicating the right slope of the project.

Step 2

Place the stakes blocking the pipes with bended hook head and realized with 8 Ø steel rods with the following height: 20 cm ground depth + 10 cm concrete laying bed + pipe half- diameter. These stakes shall be positioned in pairs at such a distance that the pipe can be easily placed in between and the hook head can be placed in the middle of the pipe. The distance between a pair of stakes shall be not higher than 100 cm.

Step 3

On the bottom trench cast the concrete bed of 10 cm height at least, where the pipe shall be laid down. This bedding layer shall be perfectly flat, otherwise the whole system performance can be compromised (it is recommended the use of topographic instruments in the job site). Pay particular attention to avoiding pipe shocks that could damage it.

Step 4

Position the pipes (6 meters barrels, already perforated every 50 cm distance for connection to the ductile iron cones of Funnel, already welded half coupling with seals) and connect them among each other through coupling system and EPDM gaskets: the end parts to be connected should be perfectly clean (see the picture on the side). The 110Ø holes existing in the pipes should be turned on the upper part and aligned perfectly.

Fix the pipe by rolling around the iron wire that will be blocked to the stakes heads as described in the step 2.

Pay particular attention to avoiding pipe shocks that could damage it.

Step 5

Align and level properly. Build the flanking around the pipe, using a resistance class C25/30 concrete for the same height of the internal diameter. Pay attention to avoid that the concrete shouldn't fall down into the pipe itself (in case of installation areas subjected to heavy traffic, a pipe reinforcement around through electro- welded net 8 Ø with mesh 20x20 is required).

This operation should be done with extreme attention filling the trench for the following steps in order to avoid the pipe floating and to keep under control its alignment (if it is necessary use the topographic instruments for guaranteeing the maximum accuracy).

Step 6

After 3 hours at least, start the assembly of ductile iron FUNNEL cones inserting them in relative gaskets (it is advised to lubricate them in order to make the inserting easier). The cones are provided with coupling system in order to be jointed solidly one to each other and to guarantee the perfect alignment.

Step 7

Build the flanking around the cones using a concrete with an appropriate resistance class according to the load class (from D400 to F900). The above mentioned concrete shall be reinforced with electro- welded 10 Ø and mesh 15x15 in double layer according to specific drawings. Please build the flanking up to a height lower than the volume of ductile iron cone itself. Fill the trench for the following steps in order to straighten the cones and avoid eventual misalignment. All technical information necessary for the concrete coating of the flanking are indicated in the table "C".

Step 8

Complete the installation according to the requirements or with a road paving or with special paving (according to specific drawings). In case that the paving is 20 mm thick minimum and is realized with proper resistance class concrete and reinforcement according to the project, it is allowed to continue with the same paving up to the ductile iron cone extrados. On the contrary (paving lower than 20 mm) it is necessary to build a regular flanking as per our previous step nr 7.

In case it is necessary to make watertight the gap between the paving and the ductile iron cone, please use a wooden template to be positioned close to the cone. This template will be removed for being replaced with a bicomponent and elastic concrete mortar for watertightness use.

The users of the FUNNEL products are responsible for the installation instructions control. For any further information we kindly ask you to contact our technical department

Notes

- The quotation of the final surface layer should be higher of about 3mm than the upper grating's profile.
- In case of special paving with concrete, it is necessary to foresee expansion joints for both directions in order to absorb the horizontal shocks.
- In order to protect the ductile iron FUNNEL gratings during the concrete casting and to prevent them to get dirty and the residues of polymer concrete to fall into the pipe through the cone, we advise to cover them with plastic protections until they will be taken away after the end of the works.

18- In any case the thickness S will never be lower to $(DN/2 + X \text{ mm})$, with $X=100\text{mm}$ for class of load D400 and $X=200\text{mm}$ for classes of load E600 and F900.

15- If installation is in road crossings subject to heavy traffic (especially trucks), Class C30/37 concrete should be used.

N.B. Sizes and weights are subject to usual manufacturing tolerance values.



The best condition for an easy installation of the FUNNEL is that the slope of the pipe and the slope of the finished paving are the same. In case that it doesn't happen, due to the ground morphology or due to choices that cannot be modified according to the project, we recommend the use of "extensions" to compensate the difference of quotations.

The measurement and preparation of the single extensions will have to be executed in the job site. The extension is composed by:

- a triple depth socket that has to be inserted directly into the hole of Ø110 positioned in the corrugated pipe, that guarantees by itself a supplementary height of about 13cm.
 - a possible additional pipe as the one used in sewage system in PVC or in similar material to be cut on measure to cover the failing distance (the pipe can be "welded half coupling" type or "smooth" that could be realized "welded half coupling" in the job site after having warmed it).
- If the triple depth socket is enough, it will be possible to plan to insert the ductile iron cone directly on it.

If the height to be covered is lower than 13cm of the triple depth socket, it will be necessary to cut it on measure before inserting it. At the end, in case that the height to be covered is higher than 13 cm of the triple depth socket, the fragment of pipe will be inserted on it and therefore the ductile iron cone will be assembled to the pipe.

In case that the height of the extension is lower than 25cm, it will be needed to make the concrete coating of the flanking of "pipe + extension" with C25/30 class concrete up to a height of 5/10cm below the head of the extension.

In case that the height of the extension is higher than 25cm, it will be needed to make the concrete coating of the flanking of "pipe + extension" with a concrete mixture at 6% up to a height of 5/10cm below the head of the extension.

In order to ensure the alignment of all extensions, it is necessary to lay a wire on the whole line length in order to guarantee the right position.

Therefore the concrete with Constituency Class S4 (EN 206-1) is recommended and the rock aggregate will have to be made of stones with a maximum diameter of 8 mm. In case of intensive and frequent stressis equip the concrete around the FUNNEL with stretches of electrowelded mesh and/or steel rods.

SUMMARY TABLE

		D 400	E 600	F 900
Load class (EN 1433)				
Applicable load (EN 1433)	kN	400	600	900
Minimum height H of concrete laying bed	mm	200	200	250
Minimum thickness S of the concrete flanking ¹⁸	mm	300	350	400
Concrete compression strength class (EN 206-1)		C 25/30 ¹⁵	C 30/37	C 35/45
Concrete compression strength class ⁷ (EN 206-1)		C 30/37 XF4	C 35/45 XF4	C 40/50 XF4

18- In any case the thickness S will never be lower to (DN/2 + X mm), with X=100mm for class of load D400 and X=200mm for classes of load E600 and F900.

7- If concrete can be affected by frost and thaw cycles.

15- If installation is in road crossings subject to heavy traffic (especially trucks), Class C30/37 concrete should be used.

N.B. Sizes and weights are subject to usual manufacturing tolerance values.



INSTALLATION WITH ONE OUTLET ONLY AT THE END OF DRAINAGE LINE

FUNNEL

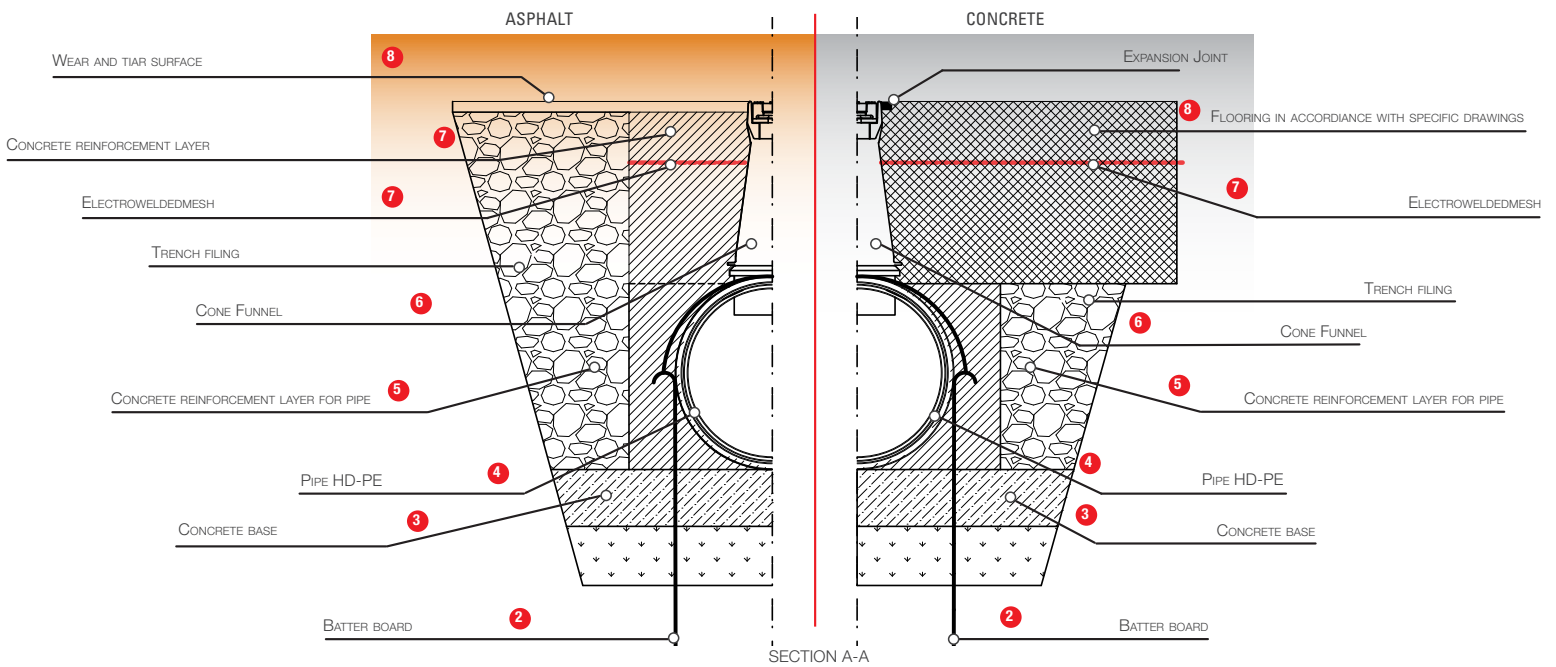
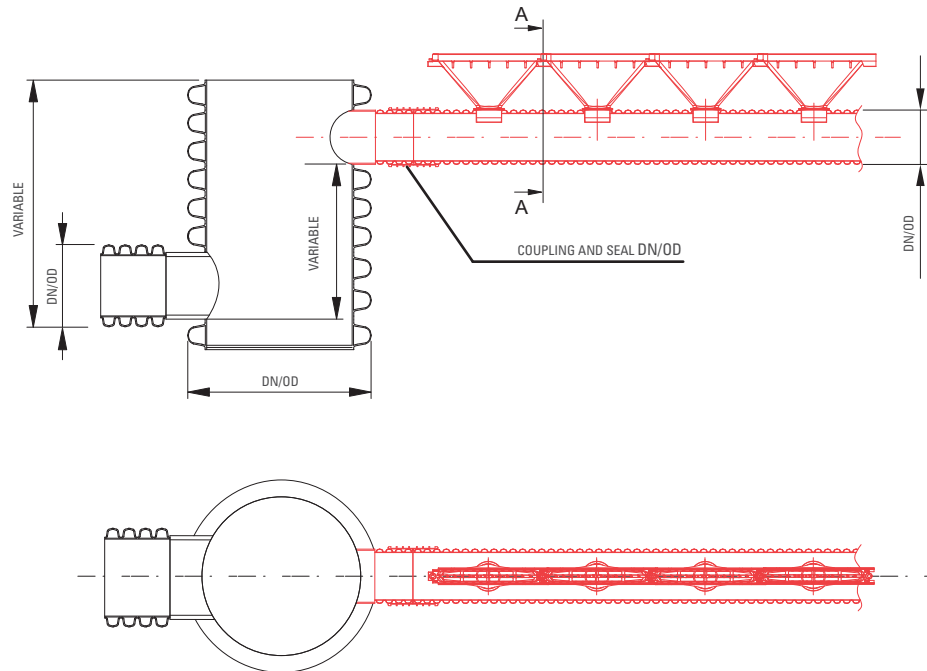

N.B. Sizes and weights are subject to usual manufacturing tolerance values.

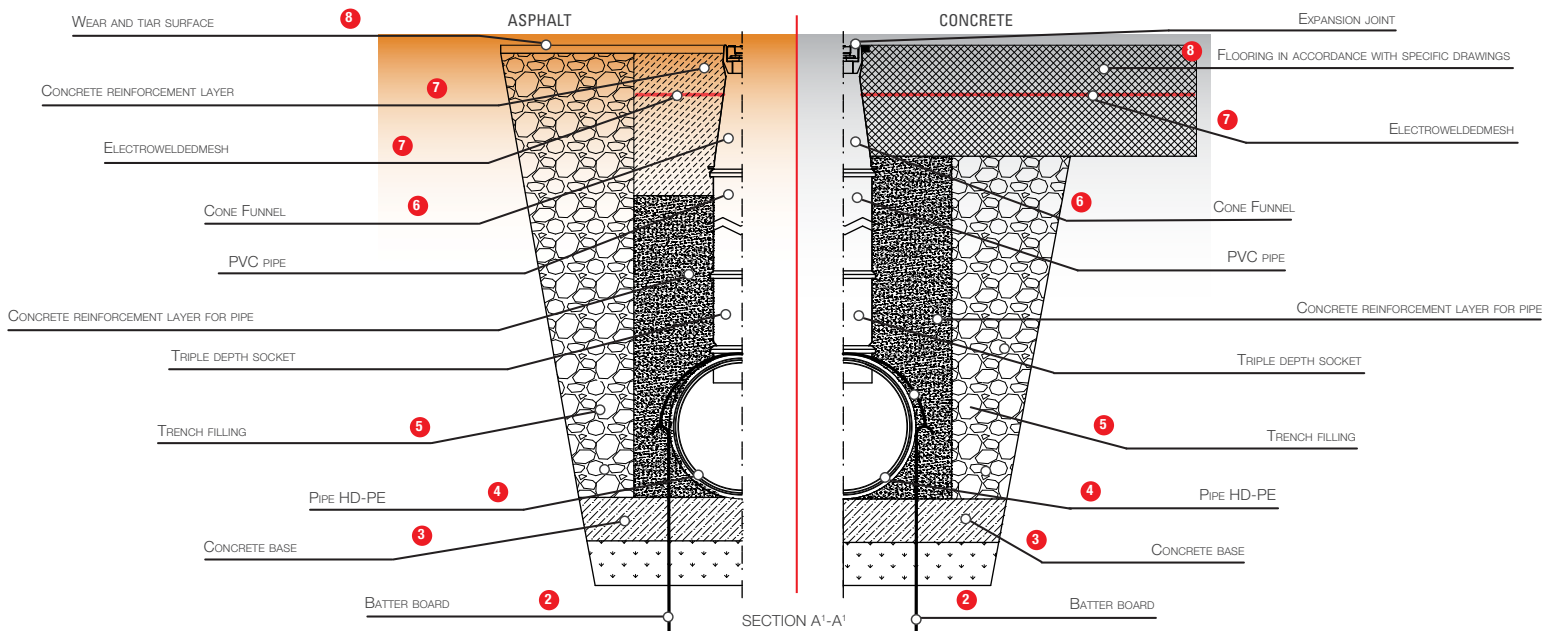
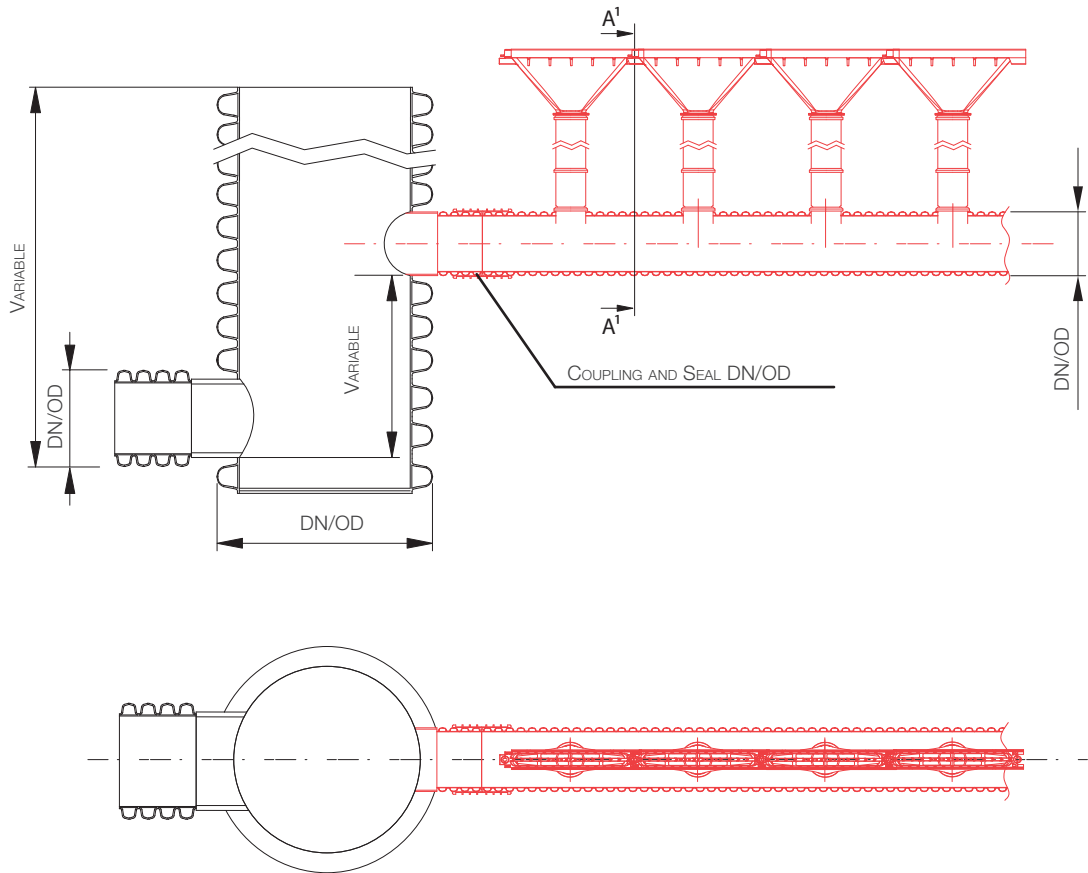

N.B. Sizes and weights are subject to usual manufacturing tolerance values.



MANHOLES COVERS AND MOULDED TEE

FUNNEL

The manholes are independent components which can be installed on line ensuring the inspection of the line itself.

The possibility of realizing the custom made manholes for pipes together with the already existing wide range of manholes with molded base allows us to change both the inferior pipe diameter and the line direction.

The moulded tee can be used as manhole for straight on lining.



EXAMPLE OF MANHOLE WITH MOULDED BASE



EXAMPLE OF MANHOLE FOR PIPES



Our technical office stays at your full disposal for any suggestion about the suitable manhole to be used (in particular with ref. to diameter, number and position of insert jointing, height) and about its installation.

N.B. Sizes and weights are subject to usual manufacturing tolerance values.



SPECIFICATIONS

FUNNEL

1. Supply and installation of the drainage system "MufleDrain FUNNEL" equipped with 3 units:

a. high density polyethylene co- extruded twin wall pipe, smooth internally and externally black corrugated for not under pressure underground sewer ducts with stiffness class SN4 (8) kN/m² and with jointing by HD-PE coupling and EPDM lip seal. This pipe has a diameter calculated according to the water flow rate so that the filling percentage will be not superior to 70% and is equipped with 110 Ø holes with 500mm pitch. Each hole will be provided with a EPDM gasket;

b. As above mentioned in the point A, the "Funnel" conveys into the pipe the water collected from the surface and is manufactured in ductile iron EN GJS 500/7 according to the EN 1563-2004; the funnels can be connected through male- female coupling system; the funnel shall be realized with one casting in order to assure one monolithic piece; in the upper part there will be a proper seat for the grating, realized by two 20 mm high frames coming from the same casting. The funnel has been designed with a proper seat for a M10 stainless steel screw in order not to let the screw rotate while fixing the gratings through nuts referred to in point C. The funnel body must be equipped with an inferior round part of a 56mm height and of a 110 Ø for direct connection to corrugated pipes that collect water as a sewage pipe referred to in point A.

Pipe dimensions must be the following ones: standard length 500 mm, total height 300 mm, height after connection to the sewage pipe 244 mm, upper width 75 mm.

c. Slotted grating in ductile iron GJS 500/7 according to EN 1563-2004 for water drainage, to be positioned in the "funnel" seat referred to in point B; the gratings shall be fixed to the "funnel" through a M10 stainless steel nut to be screwed to the screw shank sticking out from the under part; the gratings are equipped on both short sides with 2 elliptic eyelets. The eyelets will be positioned staggered so that the upper eyelet of one grating is placed on the lower one of the previous grating while applying the gratings to the "funnel"; the screw shank will be pushed through the 2 eyelets and the nut will be screwed on. The grating shall be in F900 load class with rectangular slot and will be marked with the CE-marking and with all the markings according to the EN 1433-2008. The sizes of grating shall be the following: standard length 498 mm, standard width 60 mm.